

Installation Instructions

Surface Fixed

Tembos Blues
Page 1 of 3

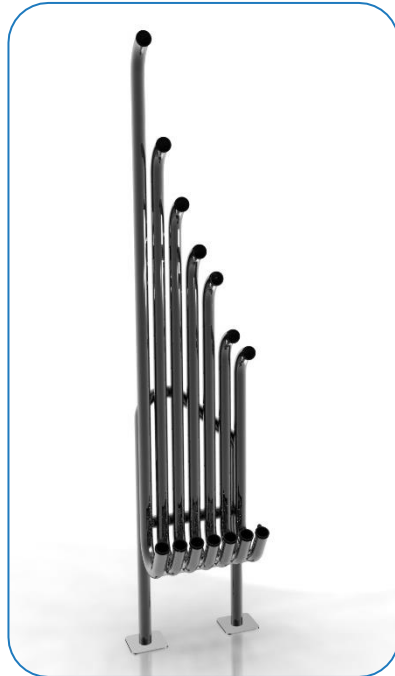

Weight of heaviest part 70kg (Tembo Frame)

1. Locate Tembos frame onto legs and, and bolt into place using pre drilled holes, **2 bolts per post.**(See Assembly Guide)

2. Attach Surface Fixing posts to legs(1.2) (See Ground Fix Post Installation Sheet)

3. Locate Instrument in desired location and mark holes to fix to desired surface.

4. Fix to Surface using recommended ground anchors not supplied

5. Make sure all fixings are covered and secure using cover caps provided

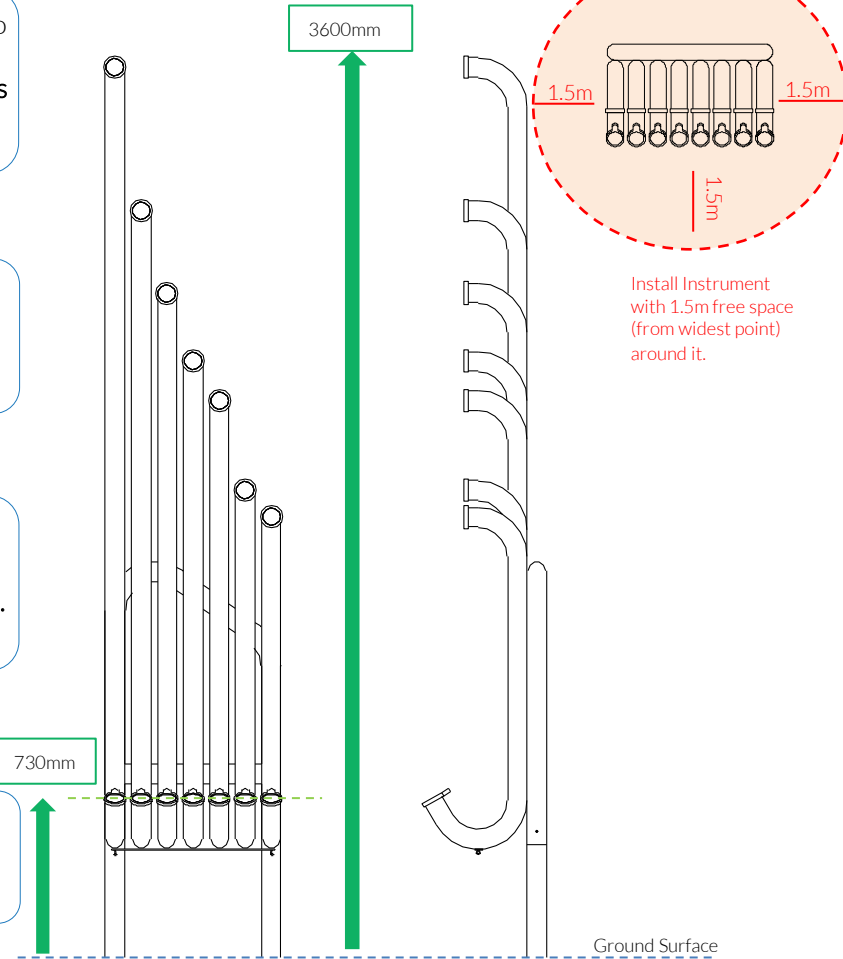

Install Instrument with 1.5m free space (from widest point) around it.

CAUTION: Tembos surface can get hot in direct sunlight, if possible install in shaded areas.

Components:



x14

M10x100 Security Screw



x28

M10 Flanged Slide Bearing



x2

M6 Eye Bolt

Metric Conversion:
730mm/ 28 47/64"
1.5m/ 59"
3600mm/ 141 47/64"



Pair Neoprene Paddles X1

Surface Fix Components:



x4

M10x70 Security Screw



x4

M10 Barrel Nut



x8

2 Part Cover Cap



Spares available from percussionplay.com or from your local distributor

80 Kg

Surface Fixed

Tempos Blues
Page 2 of 3



Instrument Components:



x14

M10x100 Security Screw



x28

M10 Flanged Slide Bearing



x2

M6 Eye Bolt

Thread Lock Solution
Required (Not Supplied)



BSEN 1176

Main Frame will arrive pre assembled

Thread Lock Solution
Required (Not Supplied)

CAUTION: Tempos surface can get hot in direct sunlight, if possible install in shaded areas.

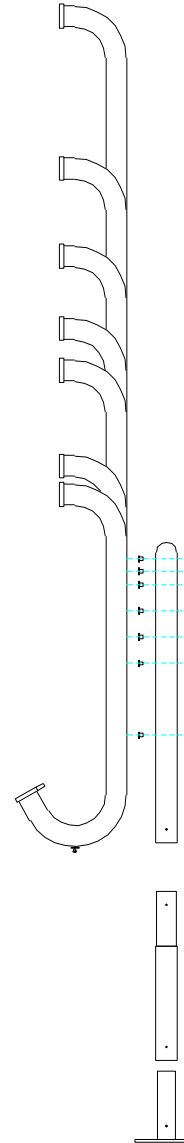
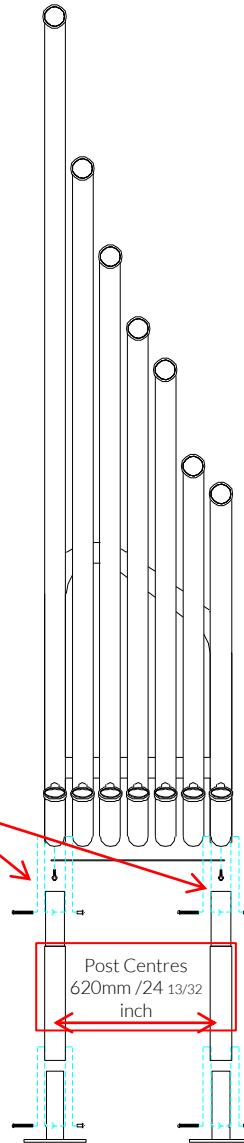

Tools:

- x1
- x2

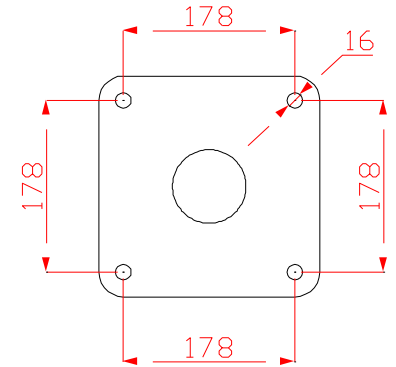

Thread Lock Solution
Required (Not Supplied)

COMPONENTS LIST:

- M6 Eye Bolt X2
- M10x70 Pin torx X4
- M10 Barrel Nut Pin torx X4
- M10x100 Pin torx X14
- M10 Black Slide Plastic Bearing X28
- SS Brace Bar X1



Pair Neoprene Paddles X1

Surface Fix Components:

x4
M10x70 Security Screw

x4
M10 Barrel Nut

x8
2 Part Cover Cap



Spares available from percussionplay.com or from your local distributor

80 Kg

Tools:

 x2
TX 45 Driver Bit

Surface Fixed

Tempos Blues
Page 3 of 3



Components:



x4

M10 Barrel Nut



x4

M10x70 Security Screw



x8

2 Part Cover Cap

Thread Lock Solution
Required (Not Supplied)

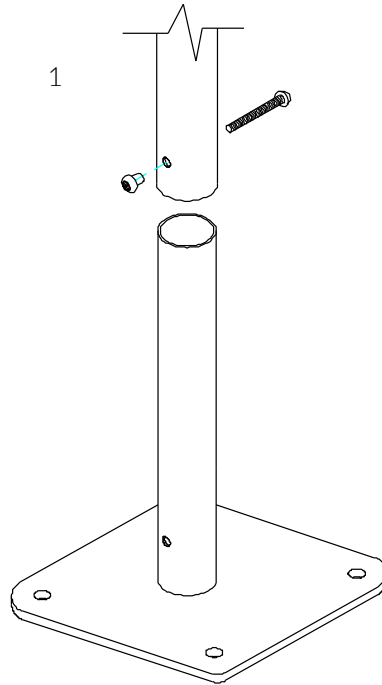

1
Locate the Surface fix Plate into the leg of the instrument.

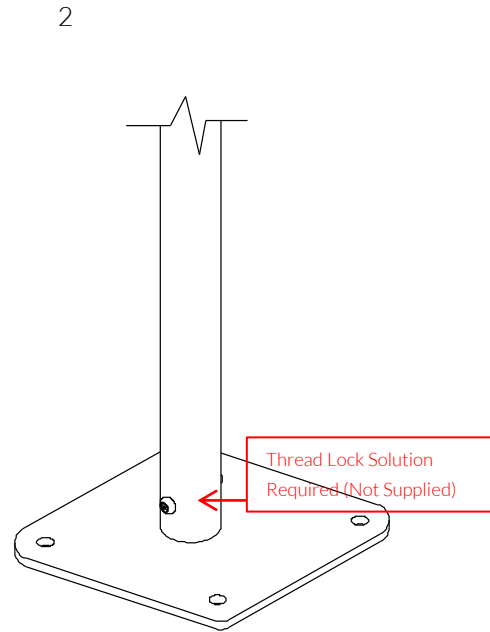

2
Fix instrument to Surface fix plate using M10 bolt and Barrel Nut and use **thread locking solution** to prevent fixings working loose.

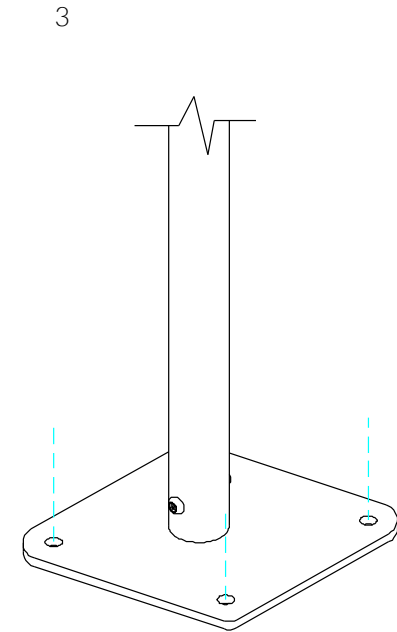

3
Fix Surface Plate to the ground surface **Ground Anchors Not provided** cover fixings with caps provided

Repeat Parts 1-3 for both legs



MADE IN
BRITAIN

BSEN 1176

